

# 1.25Gbps Bi-Di SFP Transceiver (SFP-GE-BX-U/D)

20km 1310nm /1550nm or 1310/1490

## Features

- Up to 1.25Gbps data links
- 1310nm/1550nm wavelength laser or 1310/1490nm
- Hot-Pluggable
- Single LC connector or SC
- Up to 20 km on 9/125µm SMF
- Monitoring Interface Compliant with SFF-8472
- Compliant to IEEE 802.3Z Gigabit Ethernet & SFP MSA
- Manufactured in an ISO 9001 compliant facility
- Operating temperature range: 0°C to 70°C
- ROHS-6 Compliant



## Applications

- Ethernet Switch and Enterprise Router
- Metro Ethernet and Fibre Channel
- Other Optical Links

## Part numbers

<i>P/N</i>	<i>Data Rate</i>	<i>Wavelength</i>	<i>Connector</i>	<i>Distance</i>
UBSFP-1LR35	1.25Gbps	1310Tx/1550Rx	LC	20km
UBSFP-1LR53	1.25Gbps	1550Tx/1310Rx	LC	20km
UBSFP-1LR35-SC	1.25Gbps	1310Tx/1550Rx	SC	20km
UBSFP-1LR53-SC	1.25Gbps	1550Tx/1310Rx	SC	20km
UBSFP-1LR34	1.25Gbps	1310Tx/1490Rx	LC	20km
UBSFP-1LR43	1.25Gbps	1490Tx/1310Rx	LC	20km
UBSFP-1LR34-SC	1.25Gbps	1310Tx/1490Rx	SC	20km
UBSFP-1LR43-SC	1.25Gbps	1490Tx/1310Rx	SC	20km

### Absolute Maximum Ratings

Parameter	Symbol	Min.	Typical	Max.	Unit
Storage Temperature	$T_S$	-40		+85	°C
Case Temperature	$T_C$	0		70	°C
Supply Voltage	$V_{CC}$	-0.5		4	V
Relative Humidity	RH	5		95	%

### Recommended Operating Environment:

Parameter	Symbol	Min.	Typical	Max.	Unit
Case operating Temperature	$T_C$	0		70	°C
Supply Voltage	$V_{CC}$	3.14		3.47	V
Supply Current	$I_{CC}$		200	300	mA

### Electrical Characteristics ( $T_{OP} = 0$ to $75^{\circ}\text{C}$ , $V_{CC} = 3.14$ to $3.47$ Volts)

Parameter	Symbol	Min.	Typical	Max.	Unit	Note
<b>Transmitter Section:</b>						
Input differential impedance	$R_{in}$	90	100	110	$\Omega$	1
Single ended data input swing	$V_{in PP}$	250		1200	mVp-p	
Transmit Disable Voltage	$V_D$	$V_{CC} - 1.3$		$V_{CC}$	V	2
Transmit Enable Voltage	$V_{EN}$	$V_{EE}$		$V_{EE} + 0.8$	V	
Transmit Disable Assert Time	$T_{dessert}$			10	us	
<b>Receiver Section:</b>						
Single ended data output swing	$V_{out,pp}$	250		800	mv	3
Data output rise time	$T_r$		100	175	ps	3
Data output fall time	$T_f$		100	175	ps	4
LOS Fault	$V_{losfault}$	$V_{CC} - 0.5$		$V_{CC\_host}$	V	5
LOS Normal	$V_{los norm}$	$V_{EE}$		$V_{EE} + 0.5$	V	5
Power Supply Rejection	PSR	100			mVpp	6

Note:

1. AC coupled.
2. Or open circuit.
3. Into 100 ohm differential termination.
4. 20 – 80 %
5. LOS is LVTTTL. Logic 0 indicates normal operation; logic 1 indicates no signal detected.
6. All transceiver specifications are compliant with a power supply sinusoidal modulation of 20 Hz to 1.5MHz up to specified value applied through the power supply filtering network.

1.25Gbps Bi-Di SFP Transceiver (SFP-GE-BX-U/D)  
20km 1310nm /1550nm or 1310/1490



**Optical Parameters(T<sub>OP</sub> = 0 to 70°C, VCC = 3.14 to 3.47 Volts)**

Parameter	Symbol	Min.	Typical	Max.	Unit	Note
<b>Transmitter Section:</b>						
Center Wavelength	$\lambda_c$ 1310	1290	1310	1330	nm	
	$\lambda_c$ 1550	1530	1550	1570	nm	
	$\lambda_c$ 1490	1470	1490	1510	nm	
Spectral Width	$\sigma$			1	nm	
Sidemode Supression ratio	SSRmin	30			dB	
Optical Output Power	P <sub>out</sub>	-8		-3	dBm	1
Extinction Ratio	ER	9			dB	
Optical Rise/Fall Time	t <sub>r</sub> / t <sub>f</sub>			260	ps	
Relative Intensity Noise	RIN			-120	dB/Hz	
Total Jitter Contribution	TX $\Delta$ TJ			0.284	UI	
<b>Receiver Section:</b>						
Optical Input Wavelength	$\lambda_c$ 1550	1530	1550	1570	nm	
	$\lambda_c$ 1310	1290	1310	1330	nm	
	$\lambda_c$ 1490	1470	1490	1510	nm	
Receiver Overload	P <sub>ol</sub>	-3			dBm	
RX Sensitivity	Sen			-22	dBm	2
RX_LOS Assert	LOS <sub>A</sub>	-36			dBm	
RX_LOS De-assert	LOS <sub>D</sub>			-23	dBm	
RX_LOS Hysteresis	LOS <sub>H</sub>	0.5			dB	
<b>General Specifications:</b>						
Data Rate	BR		1.25		Gbps	
Bit Error Rate	BER			10 <sup>-12</sup>		
Max. Supported Link Length on 9/125 $\mu$ m SMF@1.25Gb/s	L <sub>MAX</sub>		20		km	
Total System Budget	LB	14			dB	

Note

1. The optical power is launched into SMF. Class 1 Laser Safety per FDA/CDRH and IEC-825-1 regulations.
2. Measured with PRBS 2<sup>7-1</sup> at 10<sup>-12</sup> BER

# 1.25Gbps Bi-Di SFP Transceiver (SFP-GE-BX-U/D)

20km 1310nm /1550nm or 1310/1490

## Pin Assignment

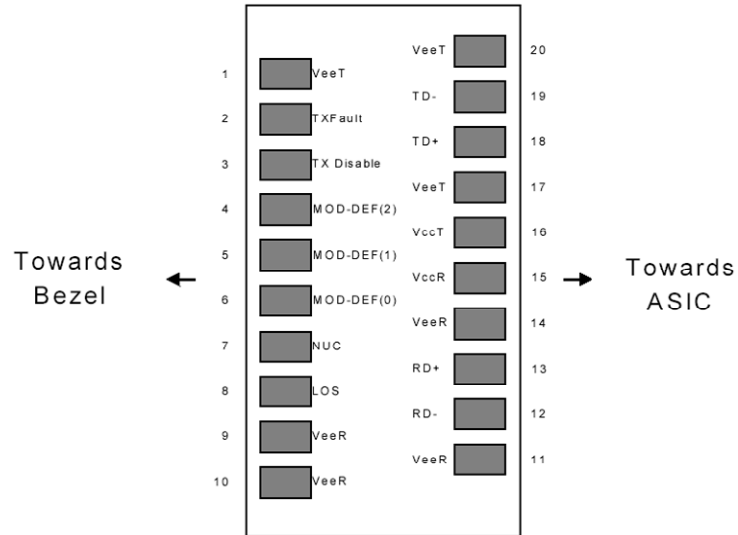

## Pin Function Definitions

Pin No	Name	Function	Plug Seq	Notes
1	VeeT	Transmitter Ground	1	1
2	TX Fault	Transmitter Fault Indication	3	
3	TX Disable	Transmitter Disable	3	2
4	MOD-DEF2	Module Definition	2	3
5	MOD-DEF1	Module Definition 1	3	3
6	MOD-DEF0	Module Definition 0	3	3
7	Rate Select	Not Connected	3	4
8	LOS	Loss of Signal	3	5
9	VeeR	Receiver Ground	1	1
10	VeeR	Receiver Ground	1	1
11	VeeR	Receiver Ground		1
12	RD-	Inv. Received Data Out	3	6
13	RD+	Received Data Out	3	6
14	VeeR	Receiver Ground	3	1
15	VccR	Receiver Power	2	1
16	VccT	Transmitter Power	2	
17	VeeT	Transmitter Ground	1	
18	TD+	Transmit Data In	3	6
19	TD-	Inv. Transmit In	3	6
20	VeeT	Transmitter Ground	1	

Notes:

# 1.25Gbps Bi-Di SFP Transceiver (SFP-GE-BX-U/D)

20km 1310nm /1550nm or 1310/1490

1. Circuit ground is internally isolated from chassis ground.
2. Laser output disabled on TDIS >2.0V or open, enabled on TDIS <0.8V.
3. Should be pulled up with 4.7k - 10 kohms on host board to a voltage between 2.0V and 3.6V. MOD\_DEF(0) pulls line low to indicate module is plugged in.
4. Rate select is not used
5. LOS is open collector output. Should be pulled up with 4.7k – 10 kohms on host board to a voltage between 2.0V and 3.6V. Logic 0 indicates normal operation; logic 1 indicates loss of signal.
6. AC Coupled

## SFP Module EEPROM Information and Management

The SFP modules implement the 2-wire serial communication protocol as defined in the SFP -8472. The serial ID information of the SFP modules and Digital Diagnostic Monitor parameters can be accessed through the I<sup>2</sup>C interface at address A0h and A2h. The memory is mapped in Table 1. Detailed ID information (A0h) is listed in Table 2. And the DDM specification at address A2h. For more details of the memory map and byte definitions, please refer to the SFF-8472, “Digital Diagnostic Monitoring Interface for Optical Transceivers”. The DDM parameters have been internally calibrated.

**Table 1.** Digital Diagnostic Memory Map (Specific Data Field Descriptions)

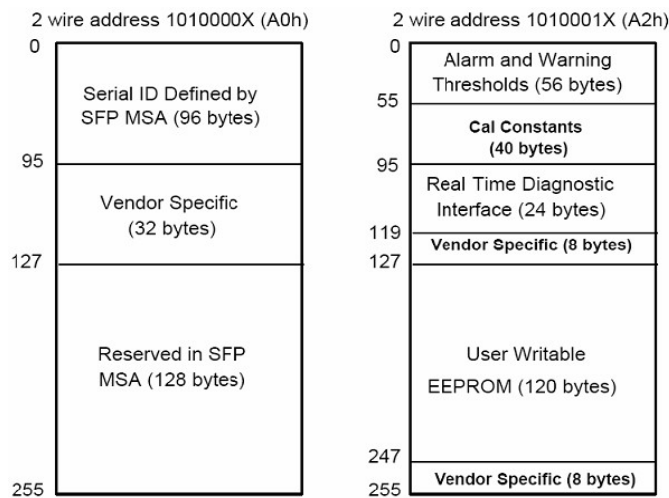

**Table 2 - EEPROM Serial ID Memory Contents (A0h)**

Data Address	Length (Byte)	Name of Length	Description and Contents
Base ID Fields			
0	1	Identifier	Type of Serial transceiver (03h=SFP)
1	1	Reserved	Extended identifier of type serial transceiver (04h)
2	1	Connector	Code of optical connector type (07=LC)
3-10	8	Transceiver	
11	1	Encoding	NRZ(03h)
12	1	BR, Nominal	Nominal baud rate, unit of 100Mbps

# 1.25Gbps Bi-Di SFP Transceiver (SFP-GE-BX-U/D)

20km 1310nm /1550nm or 1310/1490



13-14	2	Reserved	(0000h)
15	1	Length(9um)	Link length supported for 9/125um fiber, units of 100m
16	1	Length(50um)	Link length supported for 50/125um fiber, units of 10m
17	1	Length(62.5um)	Link length supported for 62.5/125um fiber, units of 10m
18	1	Length(Copper)	Link length supported for copper, units of meters
19	1	Reserved	
20-35	16	Vendor Name	SFP vendor name
36	1	Reserved	
37-39	3	Vendor OUI	SFP transceiver vendor OUI ID
40-55	16	Vendor PN	Part Number(ASCII)
56-59	4	Vendor rev	Revision level for part number
60-62	3	Reserved	
63	1	CCID	Least significant byte of sum of data in address 0-62
Extended ID Fields			
64-65	2	Option	Indicates which optical SFP signals are implemented (001Ah = LOS, TX_FAULT, TX_DISABLE all supported)
66	1	BR, max	Upper bit rate margin, units of %
67	1	BR, min	Lower bit rate margin, units of %
68-83	16	Vendor SN	Serial number (ASCII)
84-91	8	Date code	Manufacturing date code
92-94	3	Reserved	
95	1	CCEX	Check code for the extended ID Fields (addresses 64 to 94)
Vendor Specific ID Fields			
96-127	32	Readable	specific date, read only
128-255	128	Reserved	Reserved for SFF-8079

## Digital Diagnostic Monitor Characteristics

Data Address	Parameter	Accuracy	Unit
96-97	Transceiver Internal Temperature	±3.0	°C
98-99	VCC3 Internal Supply Voltage	±3.0	%
100-101	Laser Bias Current	±10	%
102-103	Tx Output Power	±3.0	dBm
104-105	Rx Input Power	±3.0	dBm

# 1.25Gbps Bi-Di SFP Transceiver (SFP-GE-BX-U/D)

20km 1310nm /1550nm or 1310/1490

## Regulatory Compliance

Electrostatic Discharge (ESD) to the Electrical Pins	MIL-STD-883E Method 3015.7	Class 1(>1000 V)
Electrostatic Discharge (ESD) to the Single LC Receptacle	IEC 61000-4-2 GR-1089-CORE	Compatible with standards
Electromagnetic Interference (EMI)	FCC Part 15 Class B EN55022 Class B (CISPR 22B) VCCI Class B	Compatible with standards
Laser Eye Safety	FDA 21CFR 1040.10 and 1040.11 EN60950, EN (IEC) 60825-1,2	Compatible with Class 1 laser product

## Recommended Circuit

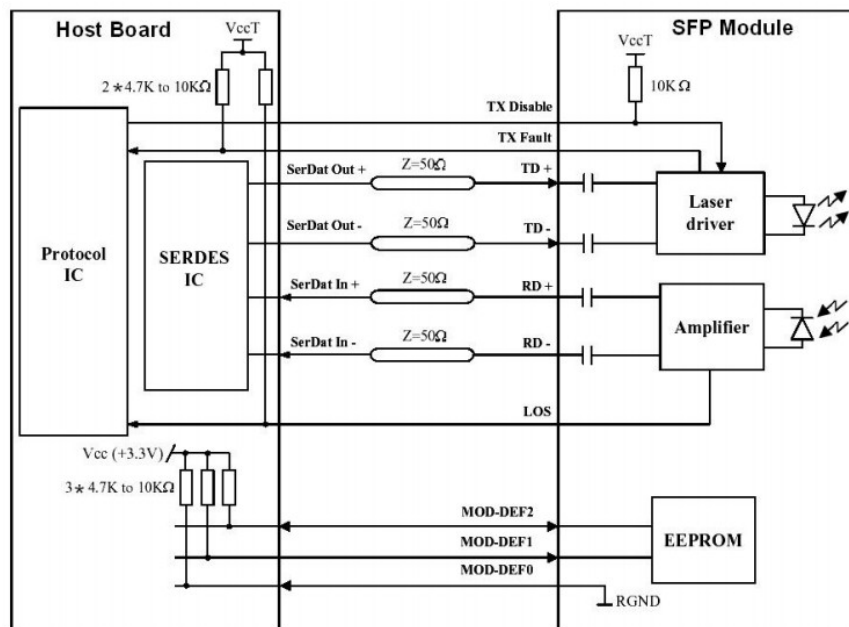

# 1.25Gbps Bi-Di SFP Transceiver (SFP-GE-BX-U/D)

20km 1310nm /1550nm or 1310/1490

## Mechanical Dimensions

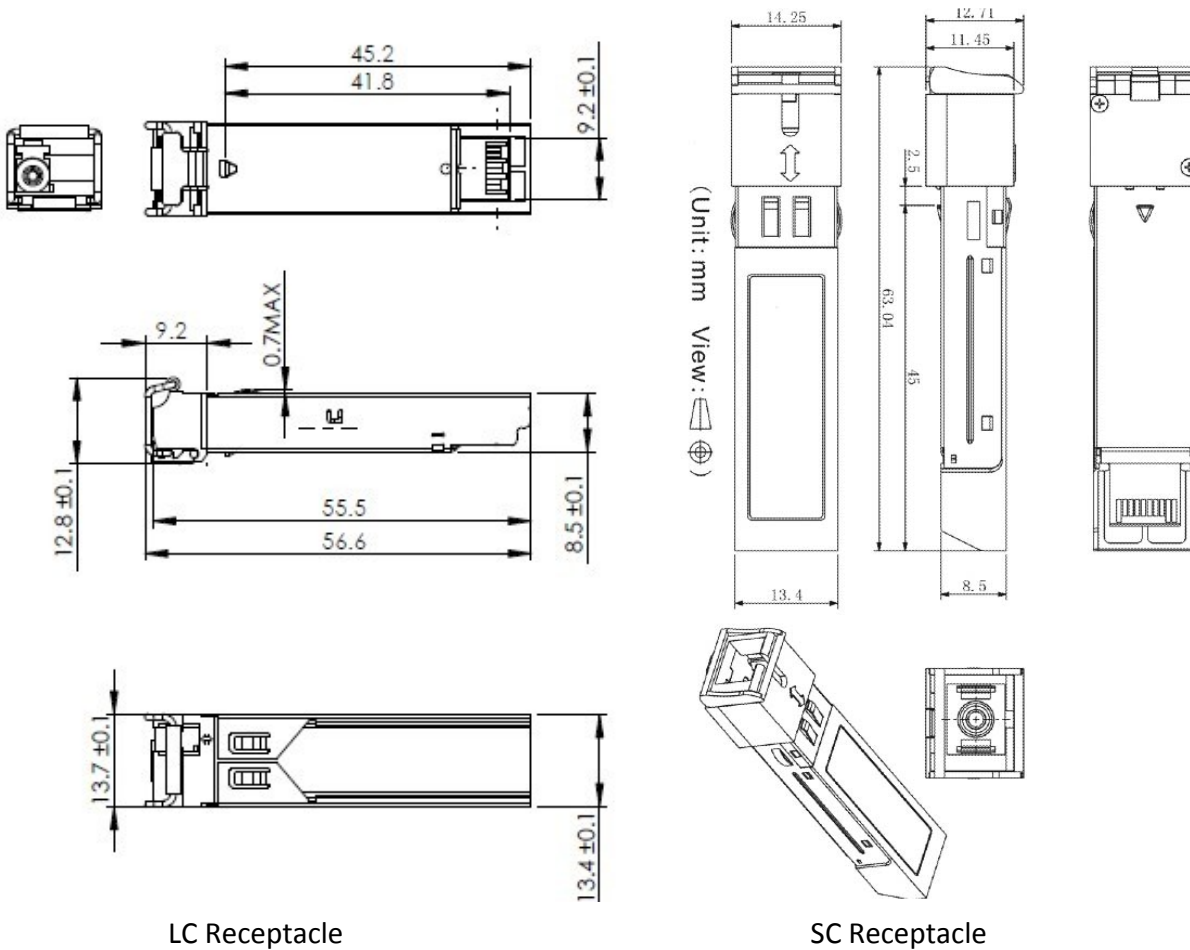

## For More Information

USource Technology  
 F8 Huameiju, Yulv RD  
 Shenzhen China 518102  
 Tel. +68-755-23014563  
[info@usourcetek.com](mailto:info@usourcetek.com)  
[www.usourcetek.com](http://www.usourcetek.com)