

10Gb/s XFP Transceiver (UXFP-ER)

Duplex LC connector, +3.3V, 40km
1550nm, Single-mode

Features:

- Support multi protocol from 9.95Gb/s to 11.3Gb/s
- Hot pluggable 30 pin connector
- Compliant with XFP MSA, IEEE 802.3ae
- Transmission distance of 40km over single mode fiber
- Cooled EML laser transmitter.
- Duplex LC connector
- 2-wire interface for management and diagnostic monitor
- XFI electrical interface with AC coupling
- Power supply voltages : +3.3V
- Temperature range -10°C to 80°C
- Power consumption: <3W
- RoHS Compliant Part



Applications:

- 10GBASE-ER/EW Ethernet
- SONET OC-192 IR-2/SONET OC-192 IR-3/SDH STM S-64.2b/SDH STM S-64.3b
- 40km 10G FC
- Other optical links

Part numbers

<i>P/N</i>	<i>Data Rate</i>	<i>Wavelength</i>	<i>Connector</i>	<i>Distance</i>
UXFP-ER	10Gbps	1550nm	LC	40km

Absolute Maximum Ratings

Parameter	Symbol	Min	Max	Unit
Storage Temperature	T _{ST}	-40	+85	°C
Case Operating Temperature	T _{IP}	-10	+80	°C
Supply Voltage	V _{CC}	-0.5	+4.0	V

10Gb/s XFP Transceiver (UXFP-ER)

Duplex LC connector, +3.3V, 40km
1550nm, Single-mode

Electrical Characteristics (T_{OP} = 0 to 70 °C)

Parameter	Symbol	Min	Typ	Max	Unit	Note	
Supply Voltage	V _{CC}	3.13		3.45	V		
Supply Current	I _{CC}			600	mA		
Module total power	P			3	W		
Transmitter							
Input differential impedance	R _{in}		100		Ω	1	
Differential data input swing	V _{in,pp}	120		820	mV		
Transmit Disable Voltage	V _D	2.0		V _{CC}	V		
Transmit Enable Voltage	V _{EN}	GND		GND+ 0.8	V		
Transmit Disable Assert Time	T _{off}			100	ms		
Tx Enable Assert Time	T _{on}			100	ms		
Receiver							
Differential data output swing	V _{out,pp}	340	500	850	mV		
Data output rise time	t _r			35	ps	2	
Data output fall time	t _f			35	ps	2	
LOS Fault	V _{LOS fault}	V _{CC} – 0.5		V _{CCHOST}	V	3	
LOS Normal	V _{LOS norm}	GND		GND+0.5	V	3	
Power Supply Rejection	PSR	See Note 4 below					4

Notes

1. After internal AC coupling.
2. 20 – 80 %
3. Loss of Signal is open collector to be pulled up with a 4.7k – 10kohm resistor to 3.15 – 3.6V. Logic 0 indicates normal operation; logic 1 indicates no signal detected.
4. Per Section 2.7.1. in the XFP MSA Specification.

Optical Parameters(T_{OP} = 0 to 70°C)

Parameter	Symbol	Min	Typ	Max	Unit	Ref.
Transmitter						
Operating Data Rate	BR	9.95		11.3	Gb/s	
Bit Error Rate	BER			10 ⁻¹²		
Maximum Launch Power	P _{MAX}	-1		+4	dBm	1
Optical Wavelength	λ	1530	1550	1565	nm	
Optical Extinction Ratio	ER	8.2			dB	
Spectral Width	Δλ			1	nm	
Sidemode Supression ratio	SSR _{min}	30			dB	
Rise/Fall Time (20%~80%)	Tr/Tf			35	ps	

10Gb/s XFP Transceiver (UXFP-ER)

Duplex LC connector, +3.3V, 40km
1550nm, Single-mode

Average Launch power of OFF Transmitter	P_{OFF}			-30	dBm	
Tx Jitter	Txj	Compliant with each standard requirements				
Optical Eye Mask		IEEE802.3ae				2
Receiver						
Operating Data Rate	BR	9.95		11.3	Gb/s	
Receiver Sensitivity	Sen			-16	dBm	2
Maximum Input Power	P_{MAX}	0			dBm	2
Optical Center Wavelength	λ_C	1260		1600	nm	
Receiver Reflectance	Rrx			-27	dB	
LOS De-Assert	LOS _D			-17	dBm	
LOS Assert	LOS _A	-27			dBm	
LOS Hysteresis	LOS _H	0.5		5	dB	

Notes:

1. The optical power is launched into SMF.
2. Measured with a PRBS 2³¹-1 test pattern @10.3125Gbps BER≤10⁻¹².

Pin Assignment

Diagram of Host Board Connector Block Pin Numbers and Name

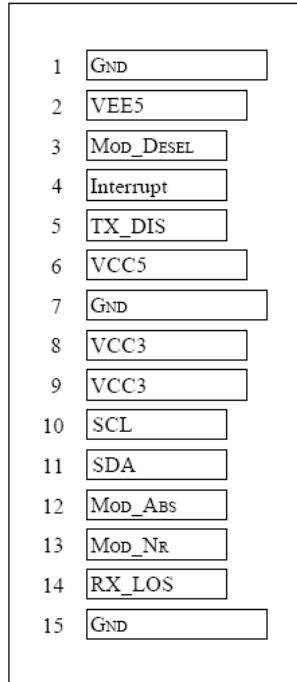

Bottom of Board
(As view through top of board)

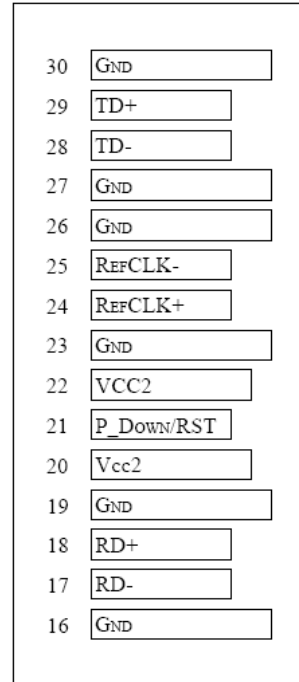

Top of Board

10Gb/s XFP Transceiver (UXFP-ER)

Duplex LC connector, +3.3V, 40km
1550nm, Single-mode

Pin Function Definitions

Pin	Logic	Symbol	Name/Description	Ref.
1		GND	Module Ground	1
2		VEE5	Optional –5.2 Power Supply – Not required	
3	LVTTL-I	Mod-Desel	Module De-select; When held low allows the module to respond to 2-wire serial interface commands	
4	LVTTL-O	Interrupt	Interrupt (bar); Indicates presence of an important condition which can be read over the serial 2-wire interface	2
5	LVTTL-I	TX_DIS	Transmitter Disable; Transmitter laser source turned off	
6		VCC5	+5 Power Supply	
7		GND	Module Ground	1
8		VCC3	+3.3V Power Supply	
9		VCC3	+3.3V Power Supply	
10	LVTTL-I	SCL	Serial 2-wire interface clock	2
11	LVTTL- I/O	SDA	Serial 2-wire interface data line	2
12	LVTTL-O	Mod_Abs	Module Absent; Indicates module is not present. Grounded in the module.	2
13	LVTTL-O	Mod_NR	Module Not Ready	2
14	LVTTL-O	RX_LOS	Receiver Loss of Signal indicator	2
15		GND	Module Ground	1
16		GND	Module Ground	1
17	CML-O	RD-	Receiver inverted data output	
18	CML-O	RD+	Receiver non-inverted data output	
19		GND	Module Ground	1
20		VCC2	+1.8V Power Supply – Not required	
21	LVTTL-I	P_Down/RST	Power Down; When high, places the module in the low power stand-by mode and on the falling edge of P_Down initiates a module reset	
			Reset; The falling edge initiates a complete reset of the module including the 2-wire serial interface, equivalent to a power cycle.	
22		VCC2	+1.8V Power Supply – Not required	
23		GND	Module Ground	1
24	PECL-I	RefCLK+	Reference Clock non-inverted input, AC coupled on the host board – Not required	3
25	PECL-I	RefCLK-	Reference Clock inverted input, AC coupled on the host board – Not required	3
26		GND	Module Ground	1

10Gb/s XFP Transceiver (UXFP-ER)

Duplex LC connector, +3.3V, 40km

1550nm, Single-mode

27		GND	Module Ground	1
28	CML-I	TD-	Transmitter inverted data input	
29	CML-I	TD+	Transmitter non-inverted data input	
30		GND	Module Ground	1

Note

1. Module circuit ground is isolated from module chassis ground within the module.
2. Open collector; should be pulled up with 4.7k – 10k ohms on host board to a voltage between 3.15V and 3.6V.
3. A Reference Clock input is not required.

Digital Diagnostic Functions

As defined by the XFP MSA 1, the module provides digital diagnostic functions via a 2-wire serial interface, which allows real-time access to the following operating parameters:

- ✓ Transceiver temperature
- ✓ Laser bias current
- ✓ Transmitted optical power
- ✓ Received optical power
- ✓ Transceiver supply voltage

It also provides a sophisticated system of alarm and warning flags, which may be used to alert end-users when particular operating parameters are outside of a factory-set normal range.

The operating and diagnostics information is monitored and reported by a Digital Diagnostics Transceiver Controller (DDTC) inside the transceiver, which is accessed through the 2-wire serial interface. When the serial protocol is activated, the serial clock signal (SCL pin) is generated by the host. The positive edge clocks data into the XFP transceiver into those segments of its memory map that are not write-protected. The negative edge clocks data from the XFP transceiver. The serial data signal (SDA pin) is bi-directional for serial data transfer. The host uses SDA in conjunction with SCL to mark the start and end of serial protocol activation. The memories are organized as a series of 8-bit data words that can be addressed individually or sequentially. The 2-wire serial interface provides sequential or random access to the 8 bit parameters, addressed from 000h to the maximum address of the memory.

For more detailed information including memory map definitions, please see the XFP MSA Specification.

10Gb/s XFP Transceiver (UXFP-ER)

Duplex LC connector, +3.3V, 40km
1550nm, Single-mode

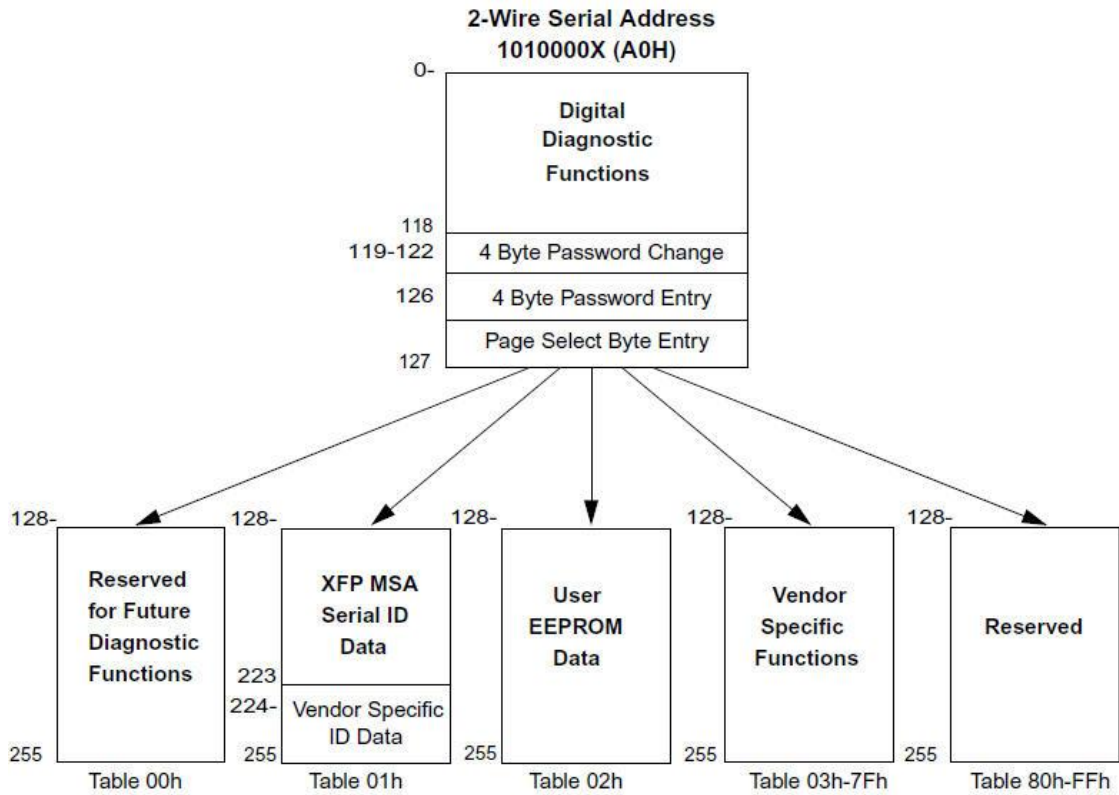

Recommended Circuit

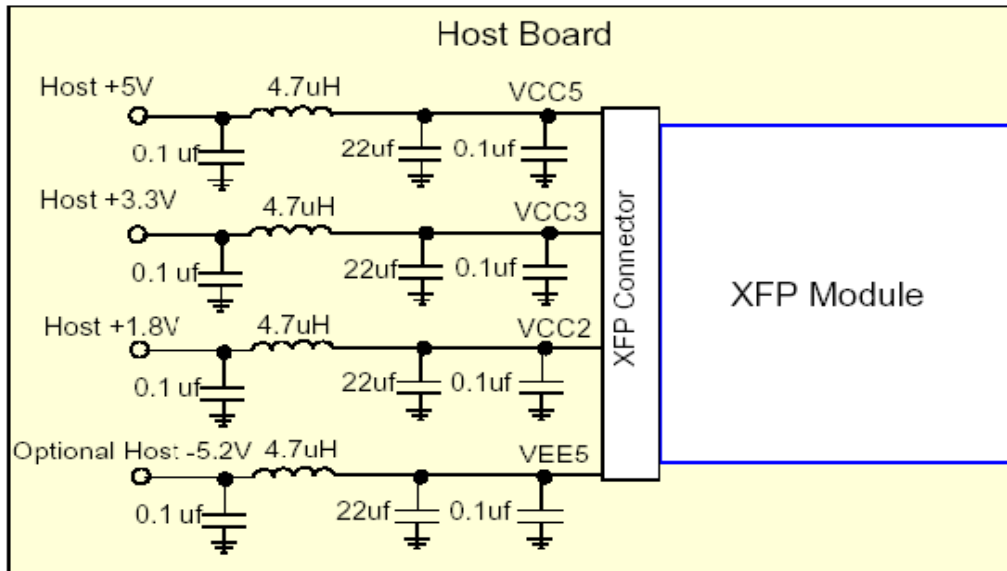

Recommended Host Board Power Supply Circuit

10Gb/s XFP Transceiver (UXFP-ER)

Duplex LC connector, +3.3V, 40km

1550nm, Single-mode

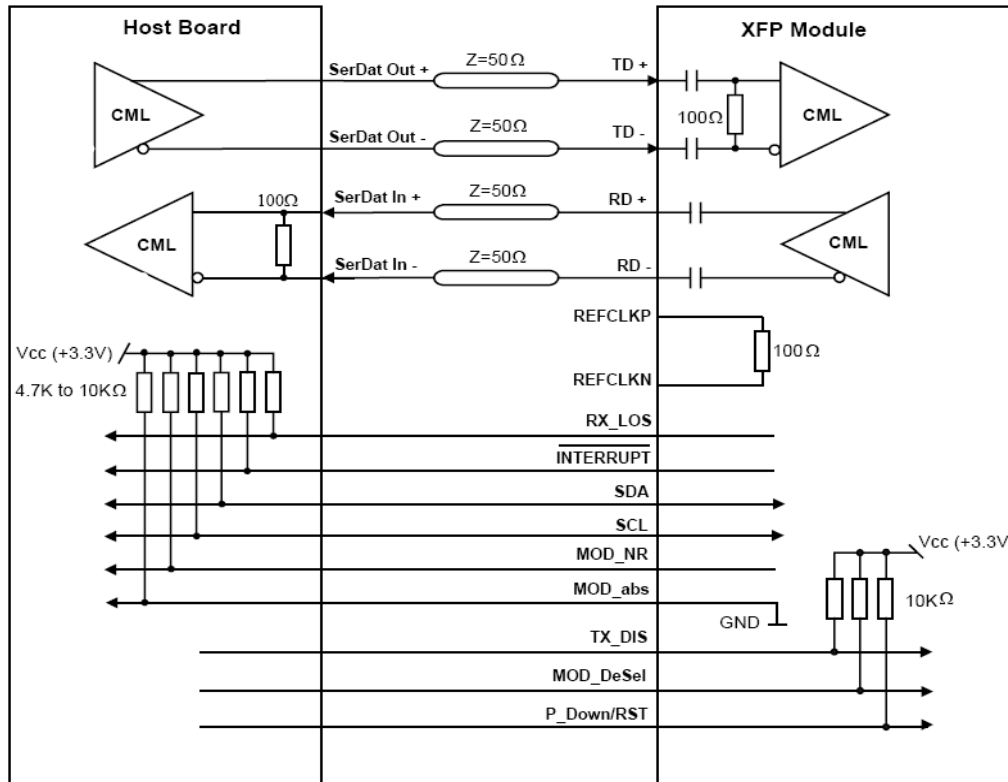

Recommended High-speed Interface Circuit

10Gb/s XFP Transceiver (UXFP-ER)

Duplex LC connector, +3.3V, 40km

1550nm, Single-mode

Mechanical Dimensions

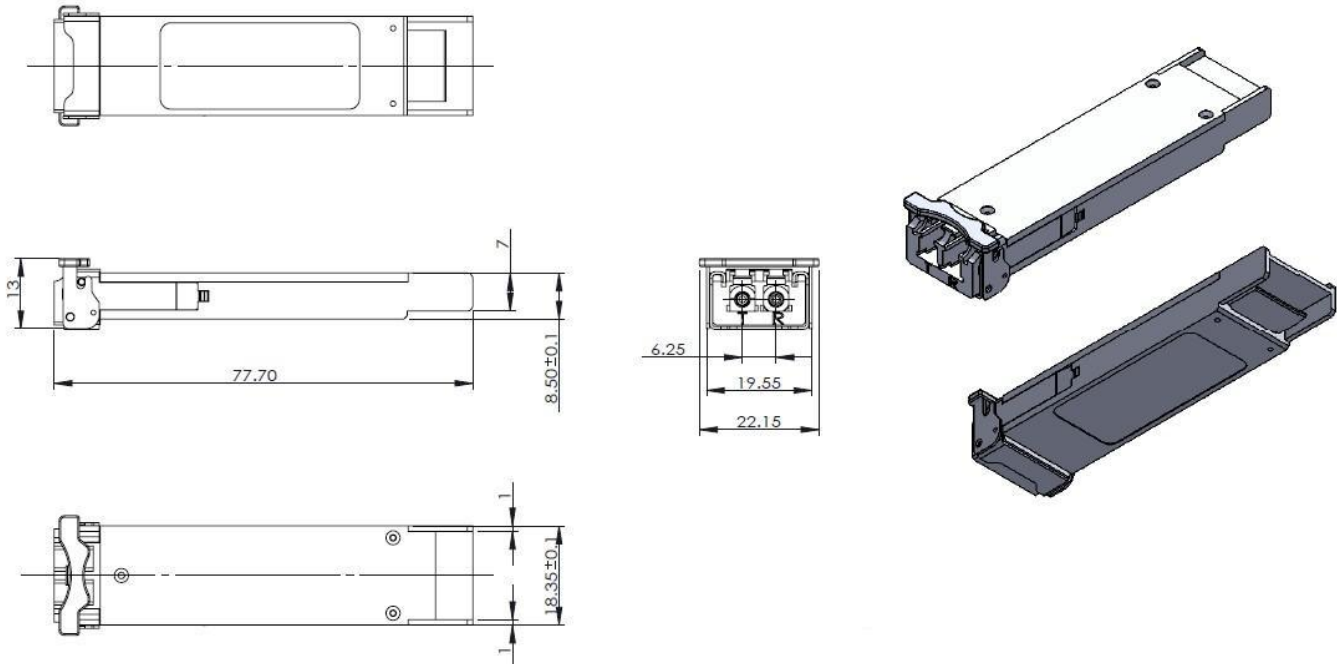

For More Information

USource Technology

F8 Huameiju, Yulv RD

Shenzhen China 518102

Tel. +68-755-23014563

info@usourcetek.com

www.usourcetek.com